

PER INFORMAZIONI PIÙ DETTAGLIATE RIVOLGERSI AL CONCESSIONARIO DI ZONA - FOR FURTHER INFORMATION PLEASE KINDLY APPLY TO OUR DEALERS

pag. 1 MOTORE 2T - 2 STROKE ENGINE

pag. 2 MOTORE 2T 2014 - 2014 2 STROKE ENGINE

pag. 3 MOTORE 2T 2002 - 2001 2 STROKE ENGINE

pag. 4 MOTORE 2T 2004 - 2004 2 STROKE ENGINE

pag. 5 RICAMBI CAMBIO BIMARCIA/FRIZIONE 3G/CILINDRO MOTARD 70
SPARE PARTS FOR 2 GEAR ENGINE/3G CLUTCH/70 MOTARD CYLINDER

pag. 6 MOTORE XP 4T 110 c.c. - XP 4T 110 c.c. ENGINE

pag. 8 RICAMBI KIT FRIZIONE - CLUTCH KIT PARTS

pag. 9 MOTORE XP 4T 125 c.c. (fino al telaio n°0229) - XP 4T 125 c.c. ENGINE (up to frame no. n°0229)

pag. 11 MOTORE XP 4T 125 c.c. (dal telaio n°0230) - XP 4T 125 c.c. ENGINE (from frame no. n°0230)

pag. 14 MOTORE XP 4T 50 c.c. - XP 4T 50 c.c. ENGINE

pag. 16 MOTORE XP 4T 150 c.c. - XP 4T 150 c.c. ENGINE

pag. 18 MOTORE XP 65 R (fino al telaio n° 162) - XP 65 R ENGINE (up to frame no. ° 162)

pag. 20 MOTORE XP 65 R 2008 (dal telaio n° 163) - XP 65 R 2008 ENGINE (from frame no. 163)

pag. 22 RICAMBI CARBURATORE POLINI CP - CP POLINI CARBURETOR SPARE PARTS



CLICCA PER ACQUISTARE
CLICK TO BUY



CONTATTA I RIVENDITORI
CONTACT OUR DEALERS

- Caratteristiche tecniche ed estetiche possono essere soggette a modifiche senza preavviso.

- Destinate esclusivamente ad uso agonistico sportivo. Ne è vietato l'uso su strada pubblica.

© POLINI MOTORI SPA, TUTTI I DIRITTI RISERVATI. I CONTENUTI DI QUESTO CATALOGO POSSONO ESSERE UTILIZZATI LIBERAMENTE A PATTO DI CITARE LA FONTE ED IL COLLEGAMENTO ALLE PAGINE INTERESSATE.

- Specifications and esthetic characteristics are subject to be changed without notice.

- They are intended solely for competition-sports usage. Use on public highways is prohibited.

© POLINI MOTORI SPA, ALL RIGHTS RESERVED. THE CATALOGUE CONTENTS CAN BE FREELY USED ON CONDITION THAT THE SOURCE AND THE LINK TO THE INTEREST PAGES ARE QUOTED.

MOTORE 2T - 2 STROKE ENGINE

MOTORE COMPLETO MONOMARCIA
 SERIE GUARNIZIONI MOTORE
 SERIE GUARNIZIONI CILINDRO
 ★ SERIE PARAOLI MOTORE Ø15
 ● COPPIA CARTER MOTORE CON CUSCINETTI E PARAOLI Ø15
 SERIE VITI PER MOTORE

ARIA	H ₂ O
144.034.001	144.034.002
144.034.003	144.034.004
144.065.001	144.065.003
144.070.001	
144.305.001	144.305.002

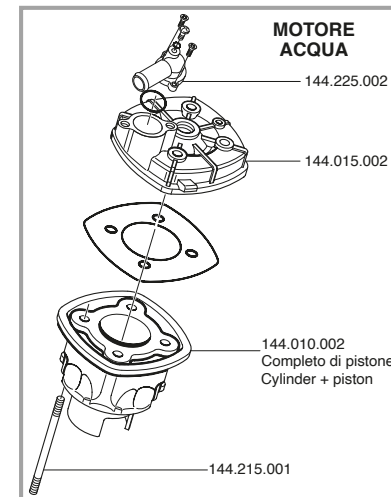
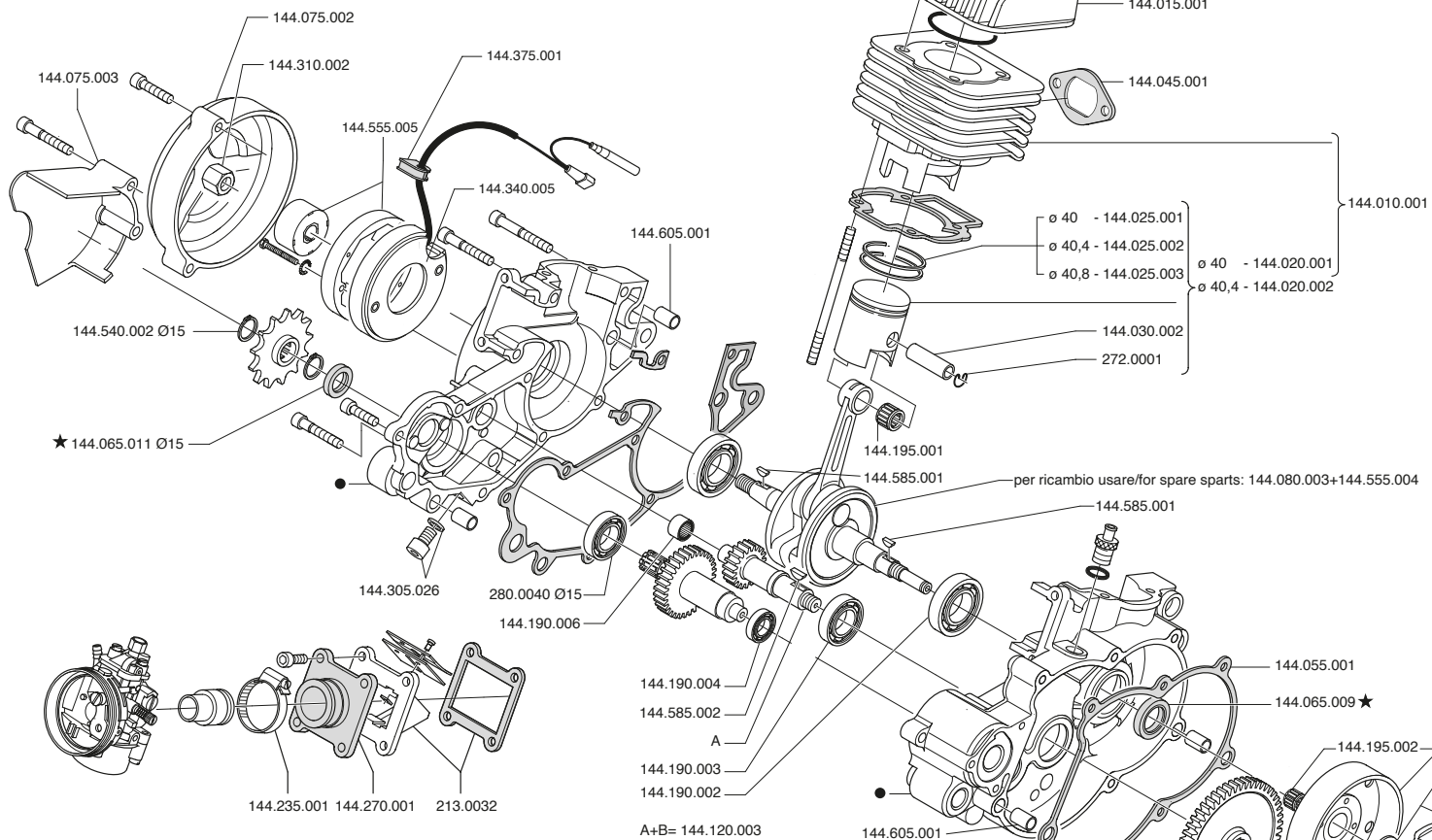

- △ Cod. 143.255.001
Set molle (ø filo: 1,6 - 2,3 - 2,3)
- Cod. 144.705.003
- Cod. 144.705.002

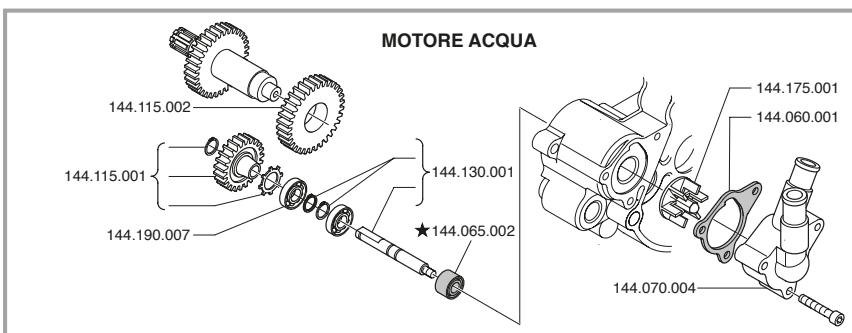
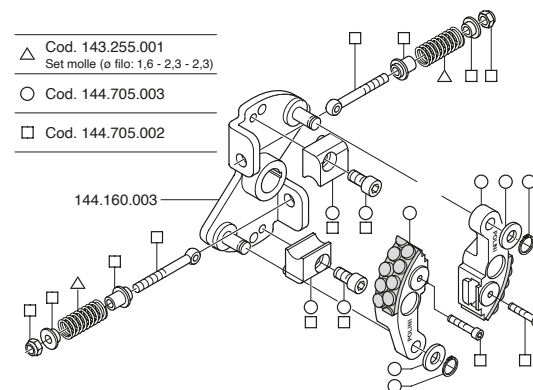

★ 144.065.010

MOTORE 2T 2014 - 2014 2 STROKE ENGINE

MOTORE COMPLETO MONOMARCIA
 SERIE GUARNIZIONI MOTORE
 SERIE GUARNIZIONI CILINDRO
 ★ SERIE PARAOLI MOTORE Ø17
 ● COPPIA CARTER MOTORE CON CUSCINETTI E PARAOLI Ø17
 SERIE VITI PER MOTORE

ARIA	H ₂ O
144.034.001	144.002.003
144.034.003	144.034.004
144.065.007	144.065.008
144.070.005	144.070.006
144.305.001	144.305.002

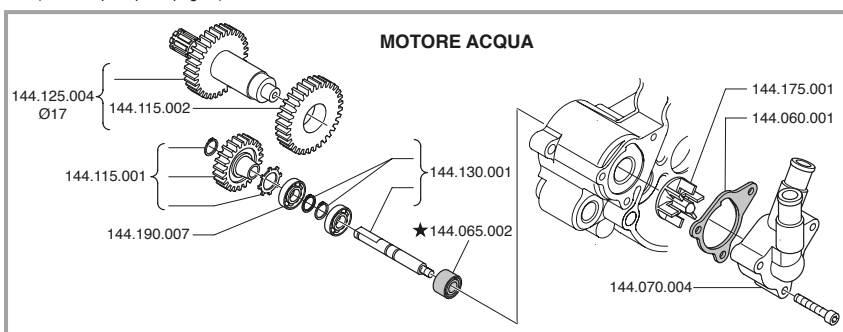
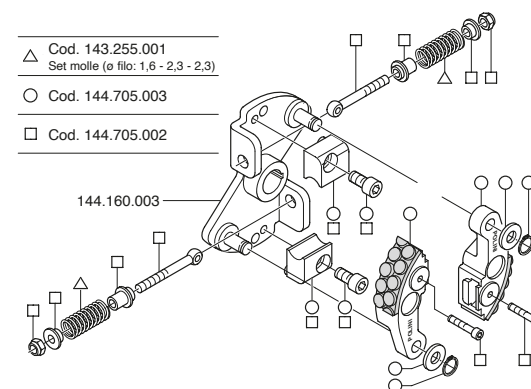
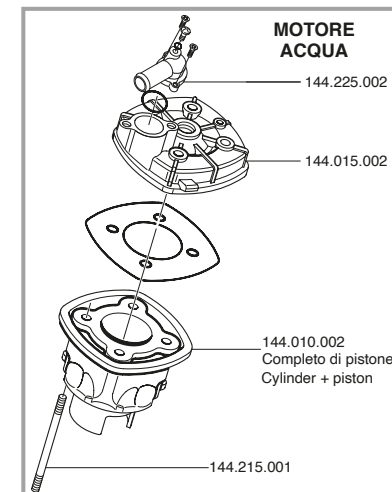
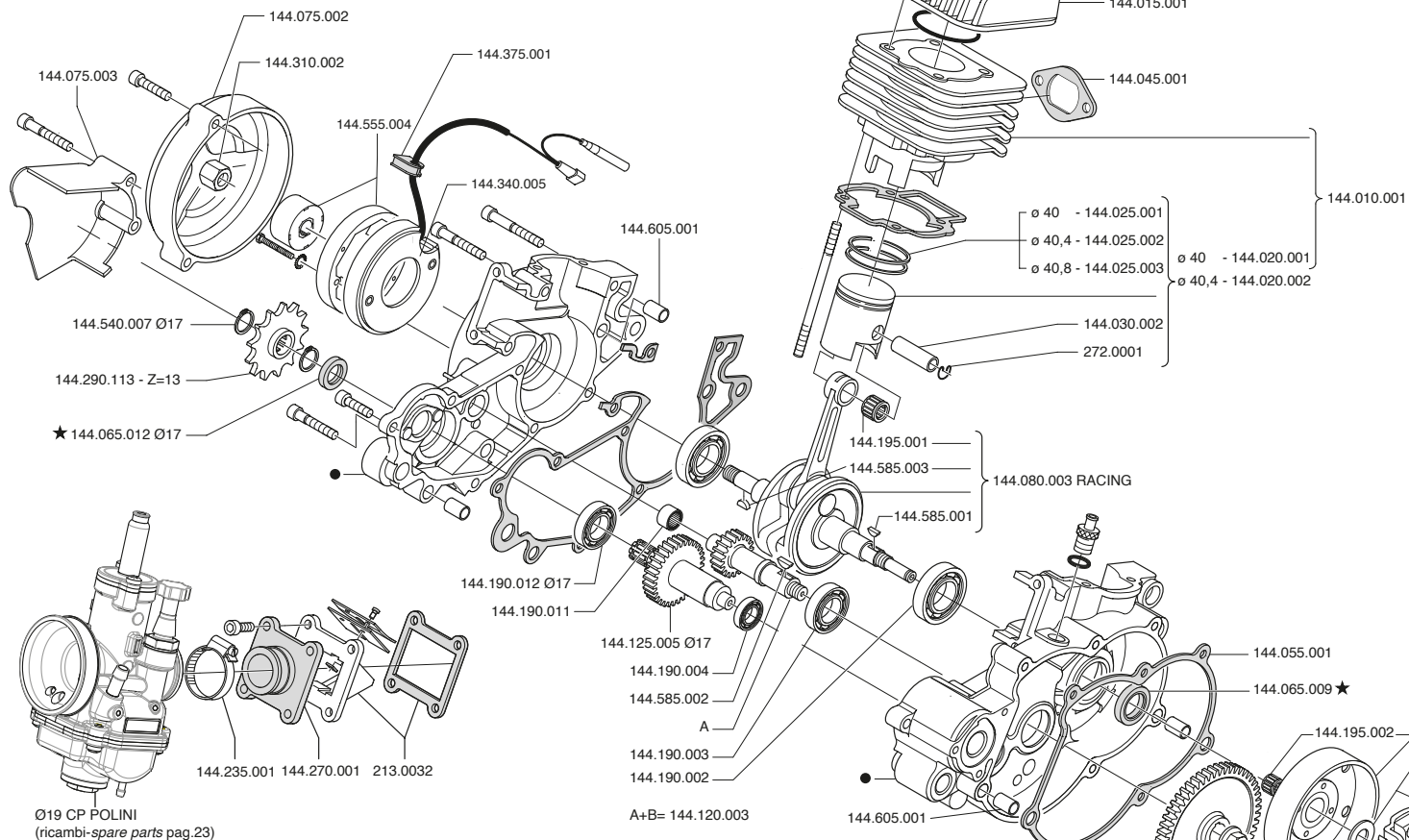

★ 144.065.010

MOTORE 2T 2002-2002 2 STROKE ENGINE

- SERIE GUARNIZIONI MOTORE 50 C.C. 144.034.007
- SERIE GUARNIZIONI CILINDRO 50 C.C. 144.034.005
- ★SERIE PARAOLI MOTORE Ø15 144.065.003

- SERIE VITI PER MOTORE 144.305.002
- ACCENSIONE COMPLETA (SELETTA) 144.004.011

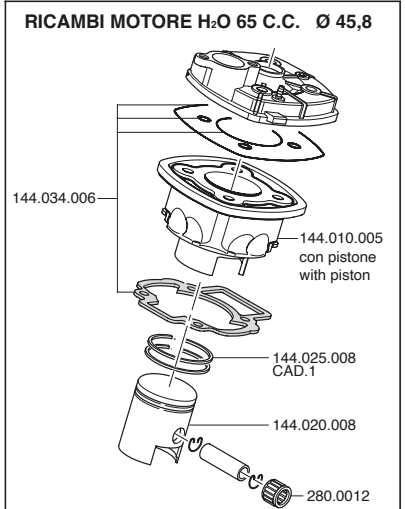
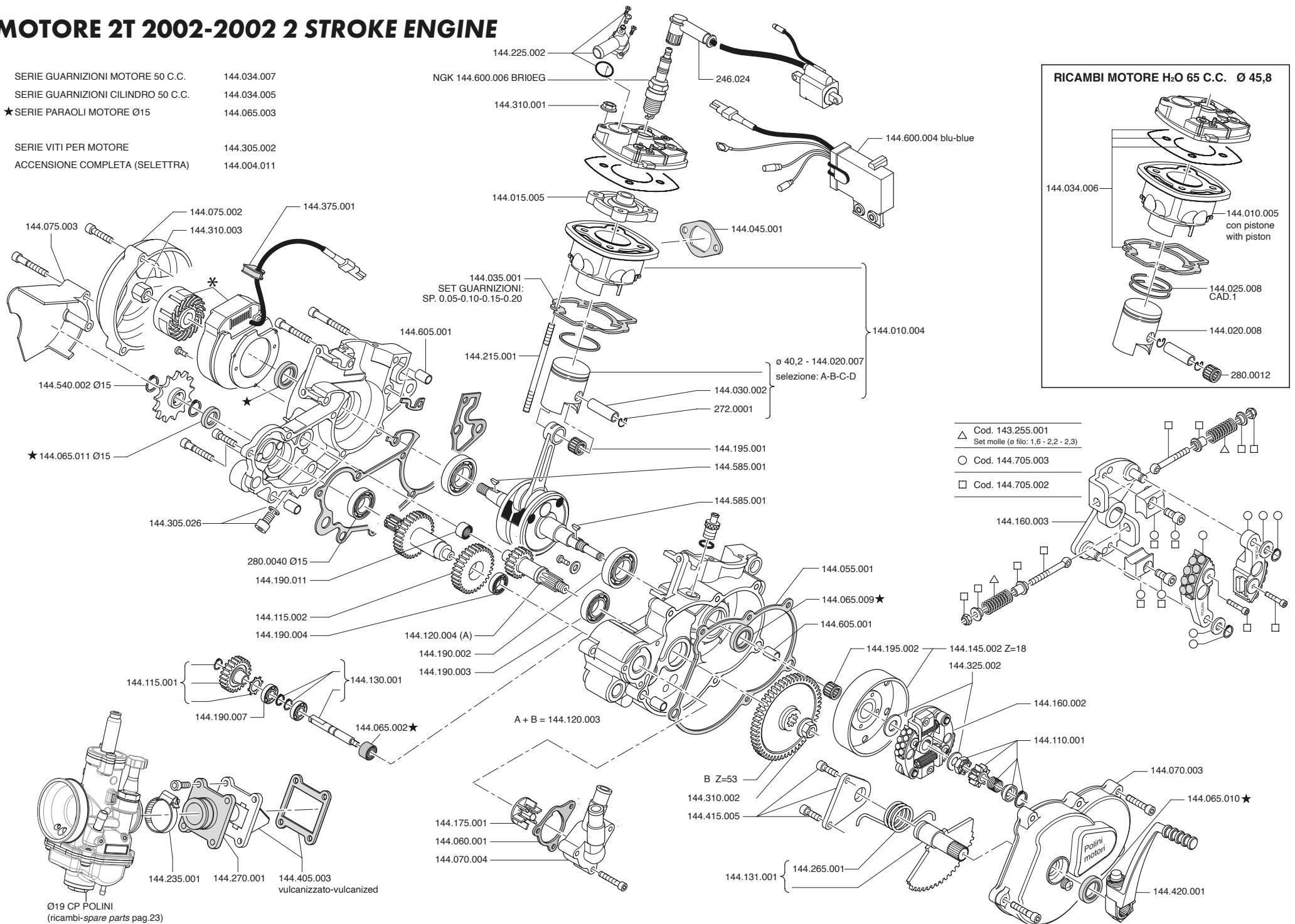

MOTORE 2T 2004 - 2004 2 STROKE ENGINE

- SERIE GUARNIZIONI MOTORE 50 C.C. 144.034.007
- SERIE GUARNIZIONI CILINDRO 50 C.C. 144.034.005
- ★ SERIE PARAOLI MOTORE Ø17 144.065.008
- COPPIA CARTER MOTORE CON CUSCINETTI E PARAOLI 144.070.006
- SERIE VITI PER MOTORE 144.305.002

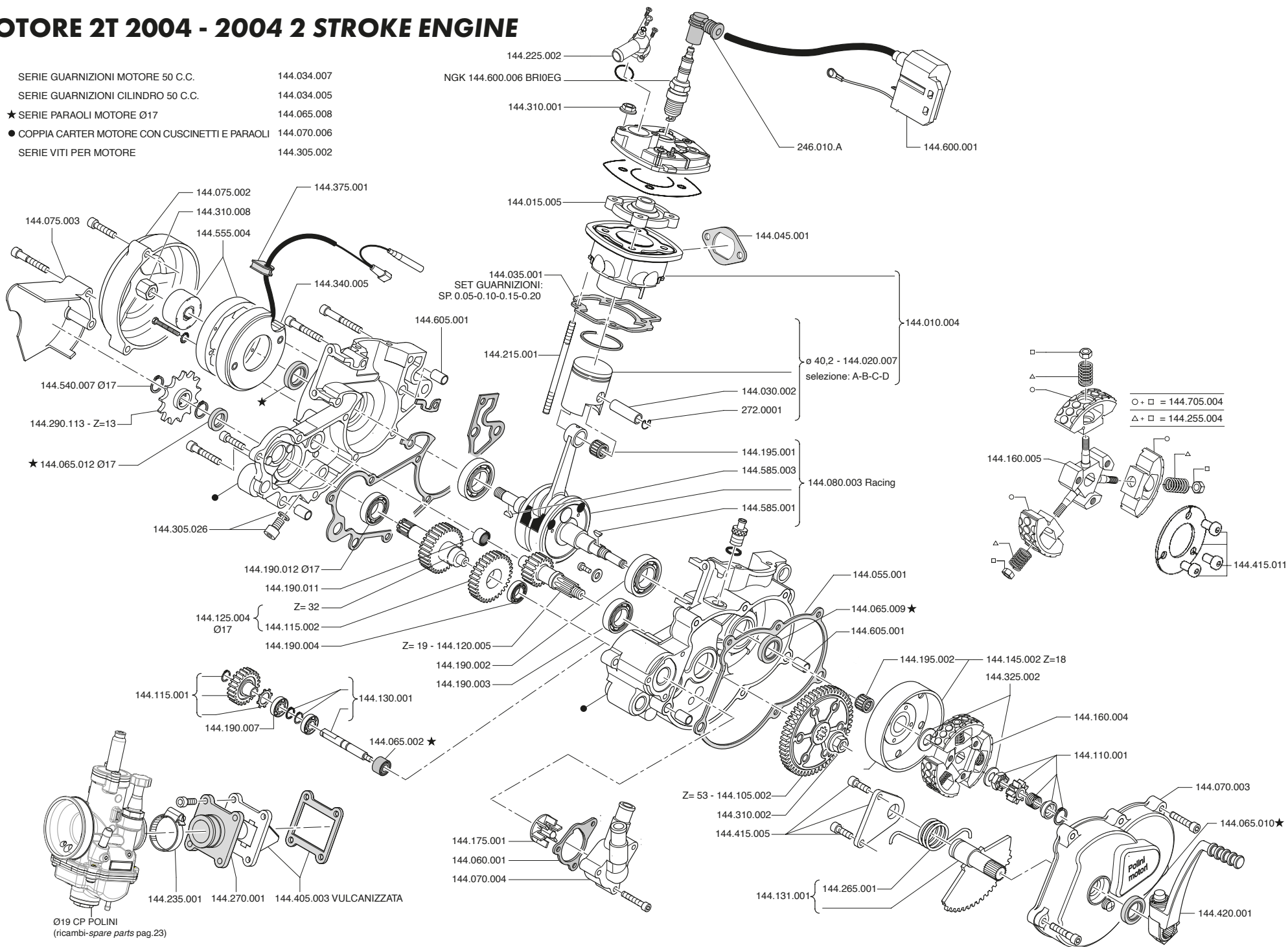

RICAMBI CAMBIO BIMARCIA 2-SPEED GEAR SPARE PARTS

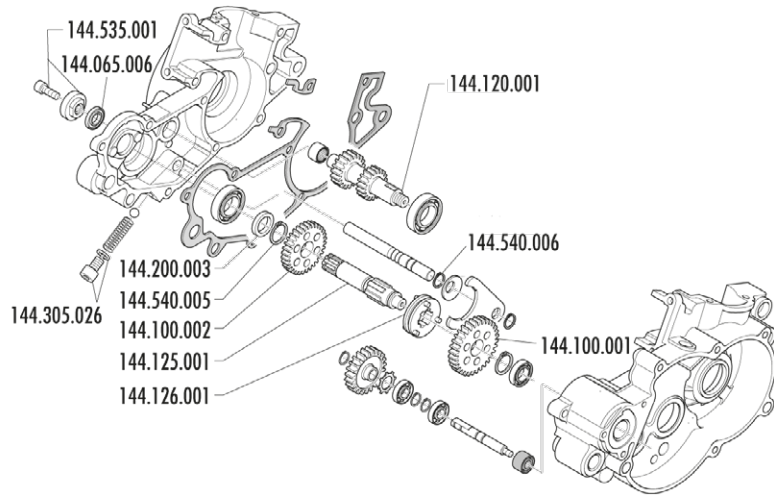

FRIZIONE 3G - 3G CLUTCH

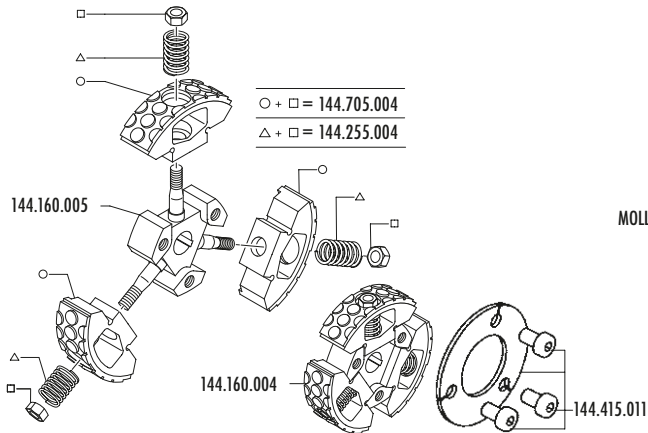

CHIAVE
REGOLAZIONE
MOLLE 144.695.005



CHIAVE FERMO
144.695.006



MOTARD 70 c.c.

Ø 47,4

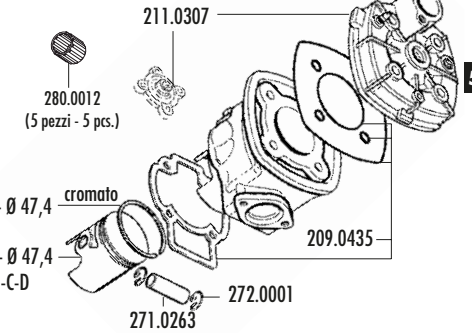
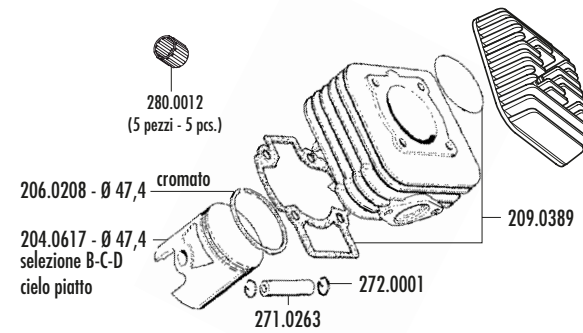

Ø 47,6

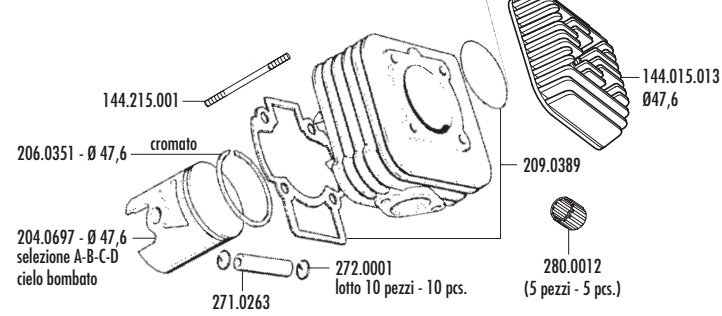

KIT 144.440.008 - DELL'ORTO VHST Ø28 XP4 110



XP 4T 110 c.c.

TESTA - COLLETTORE ASPIRAZIONE - CARBURATORE HEAD - INTAKE MANIFOLD - CARBURETOR

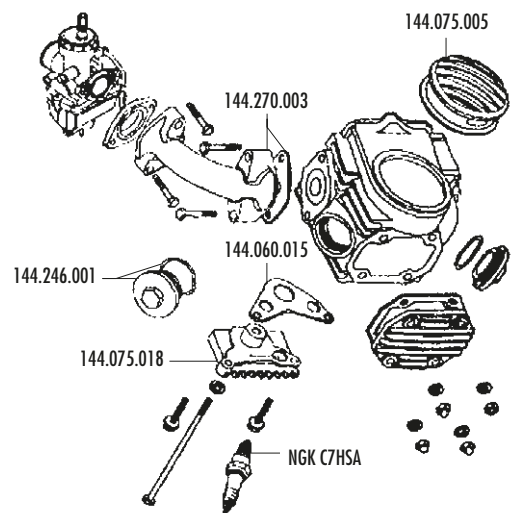

ALBERO A CAMME - VALVOLA CAM SHAFT - VALVE

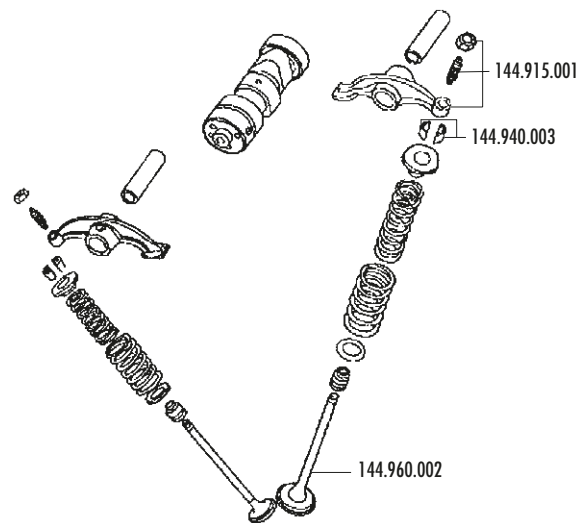

TESTA - CILINDRO HEAD - CYLINDER

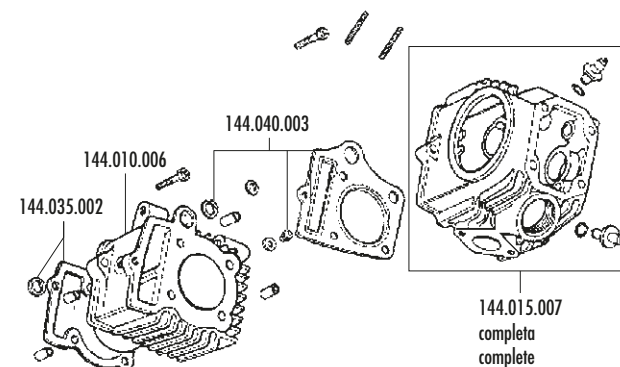

CARTER MOTORE ENGINE CRANKCASE

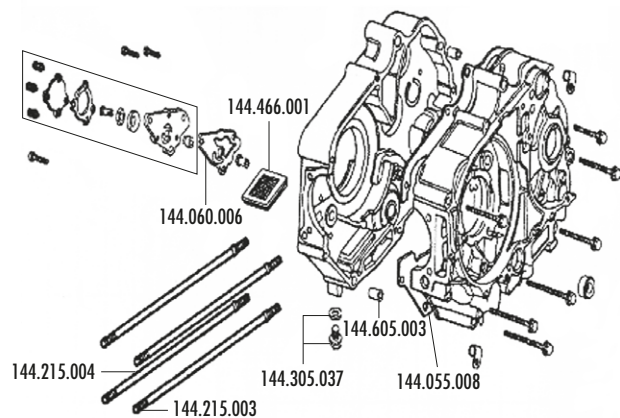

CATENA DI DISTRIBUZIONE - TENDICATENA GEARING CHAIN - CHAIN TIGHTENER

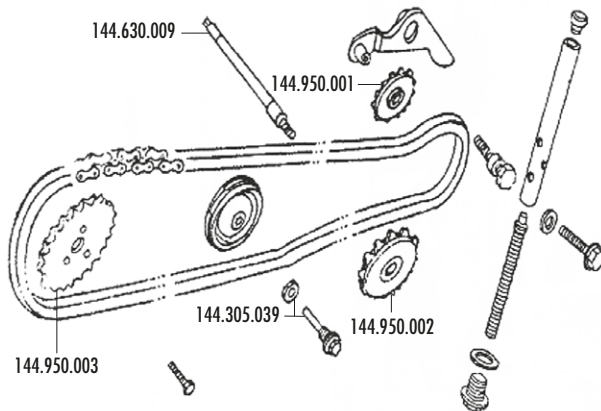

ALBERO MOTORE - CRANKSHAFT

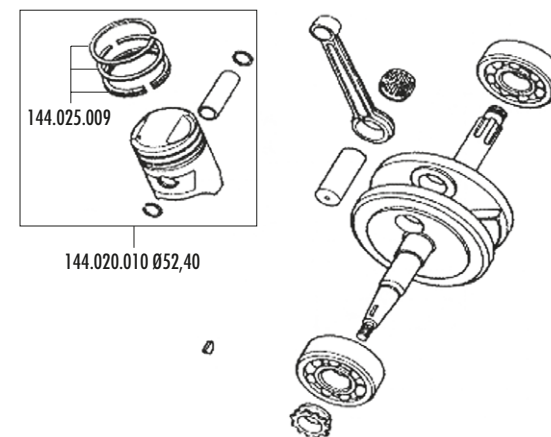

XP 4T 110 c.c.

AVVIAMENTO STARTER

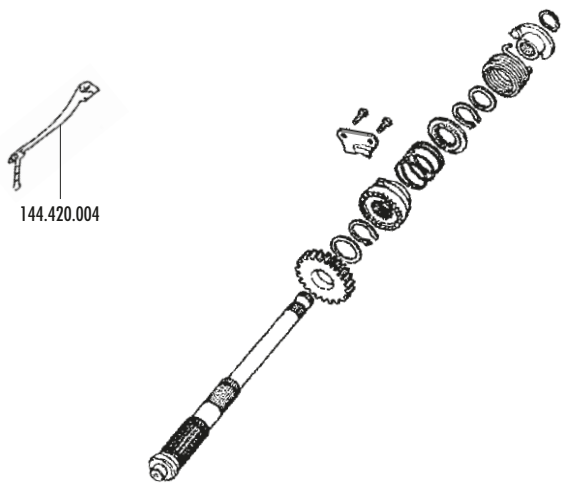

CARTER LATO FRIZIONE CLUTCH SIDE CASING

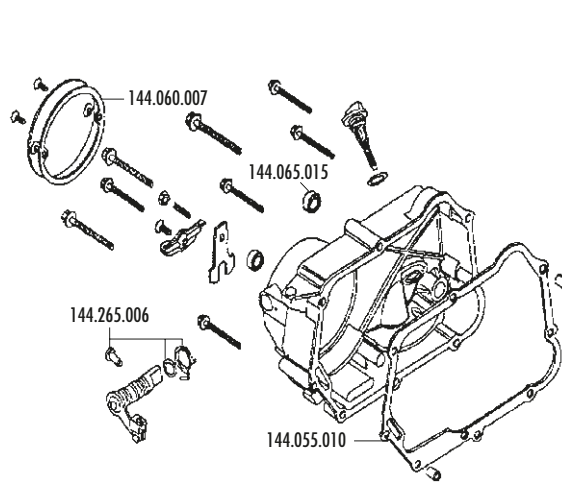

VOLANO - FLYWHEEL

BOBINA - COIL 144.600.012
CENTRALINA - CDI 144.600.013
CABLAGGIO - WIRING 144.600.001

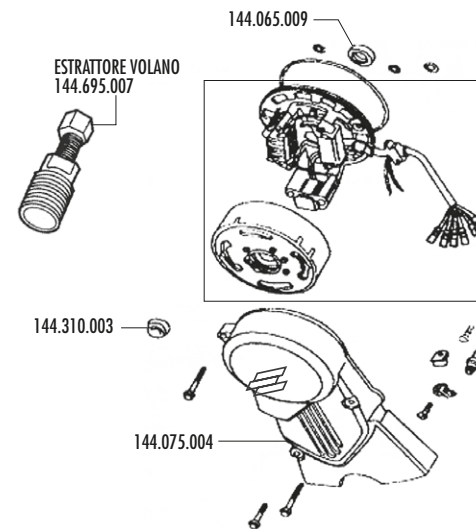

TRASMISSIONE TRANSMISSION

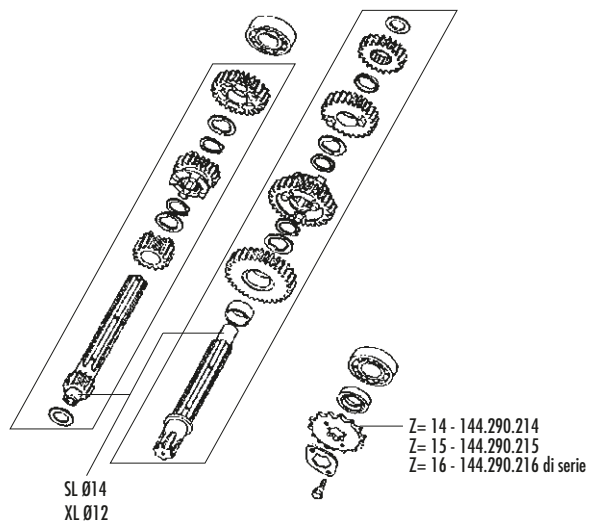

FRIZIONE CLUTCH

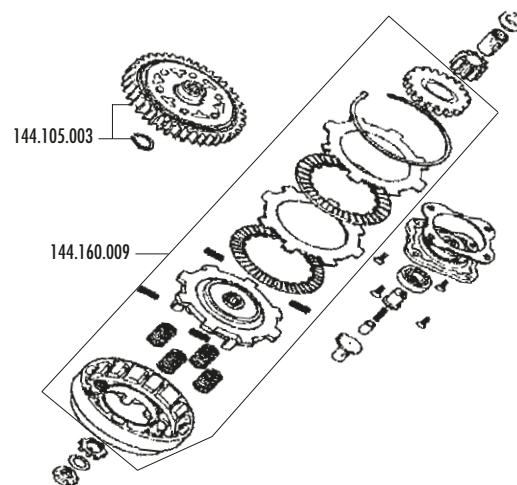

CAMBIO SHIFT

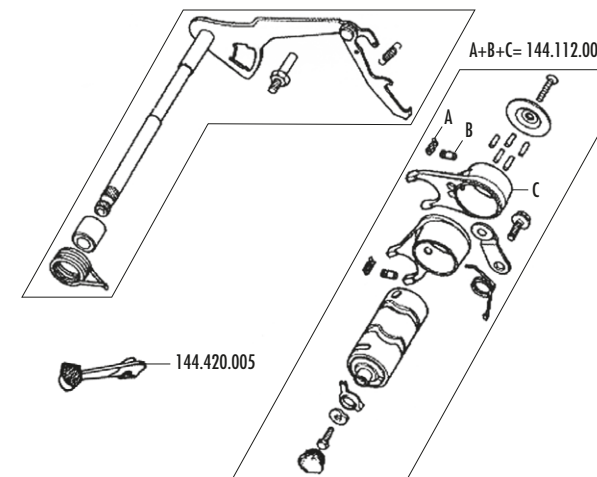

144.004.020 KIT FRIZIONE XP 4T - XP 4T CLUTCH KIT
144.004.024 KIT FRIZIONE XP 4T NEW - NEW XP 4T CLUTCH KIT

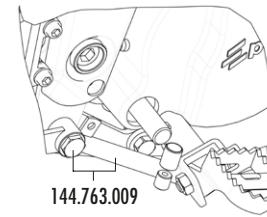
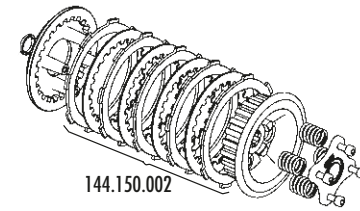
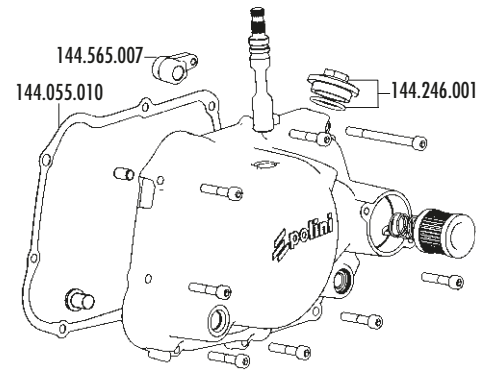

**COPERTURA TESTA
HEAD COVER**

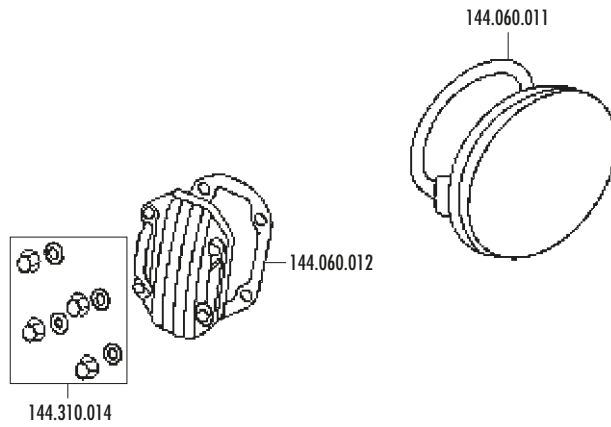

**CILINDRO
CYLINDER**

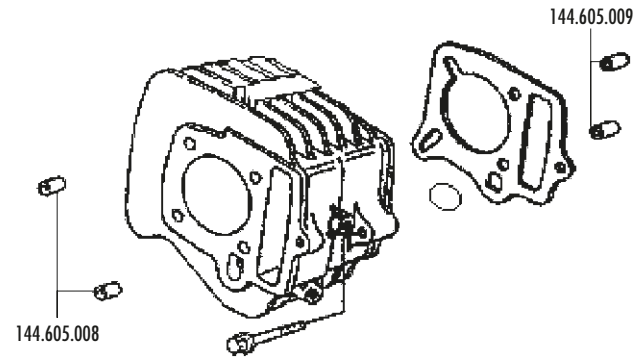

**XP4 125 c.c.
fino al telaio - up to frame
n° 0229
(Gennaio - January 2007)**

**MAGNETE
MAGNETO**

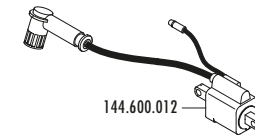

**CARTER MOTORE
ENGINE CRANKCASE**

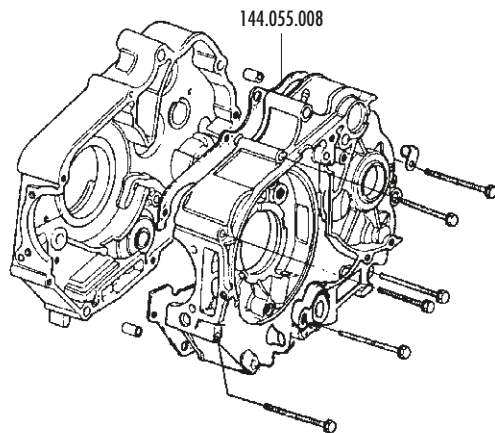

**CARTER LATO DESTRO
ENGINE CRANKCASE-RIGHT SIDE**

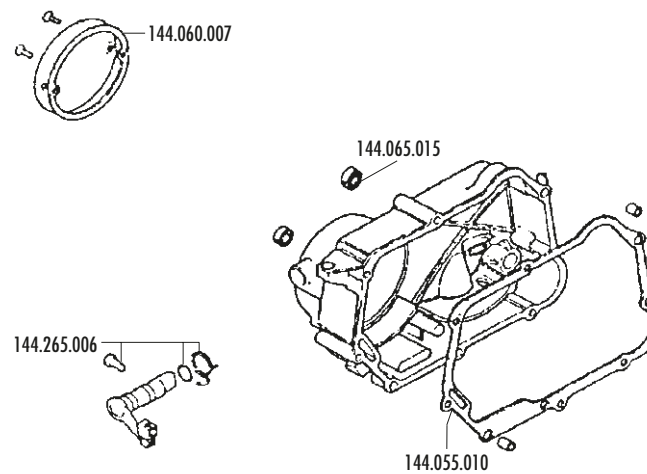

**CARTER LATO SINISTRO
ENGINE CRANKCASE-LEFT SIDE**

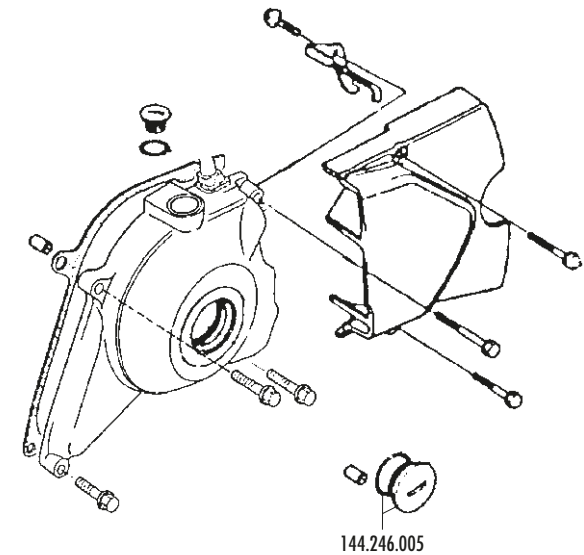

**FRIZIONE
CLUTCH**

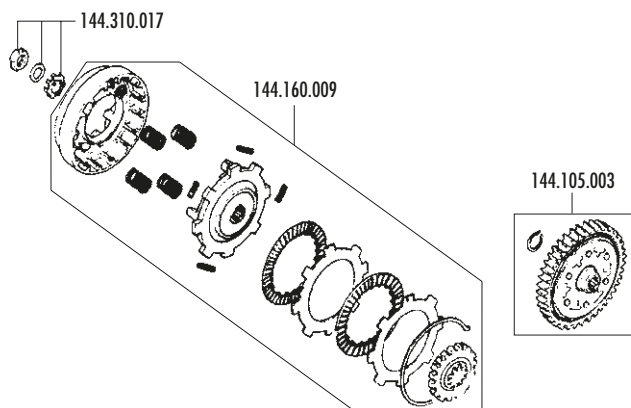

**TRASMISSIONE
TRANSMISSION**

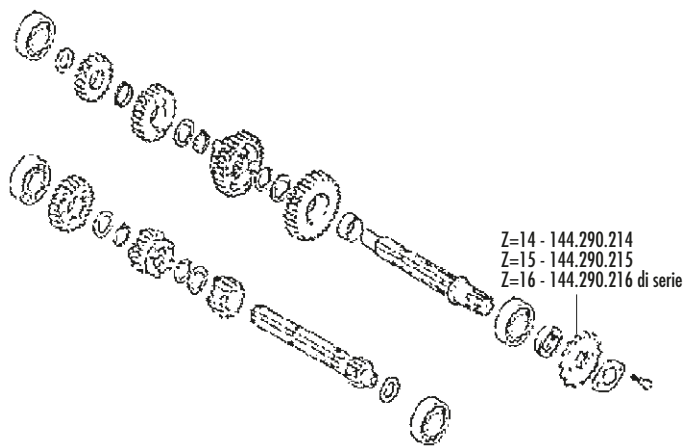

**XP4 125 c.c.
fino al telaio - up to frame
n° 0229
(Gennaio - January 2007)**

**CAMME - VALVOLE
CAM - VALVES**

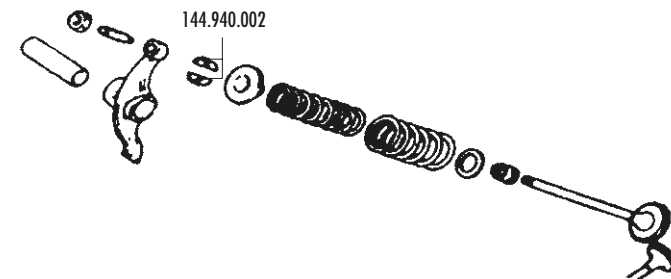

KICK STARTER

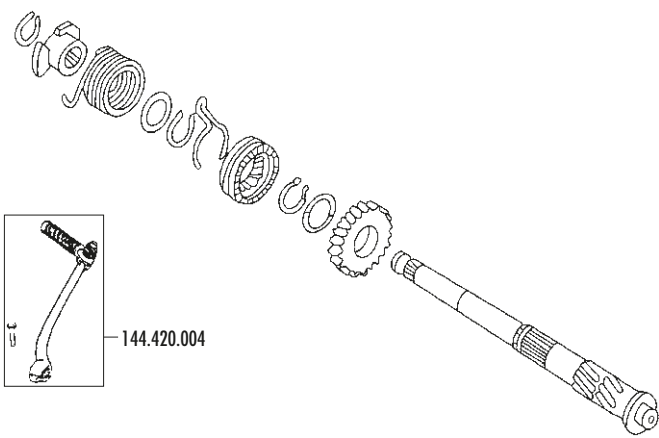

**AVVIAMENTO
STARTER**

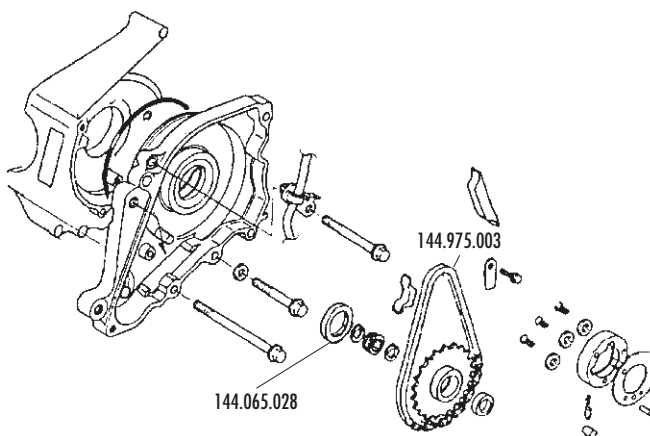

**CAMBIO
SHIFT**

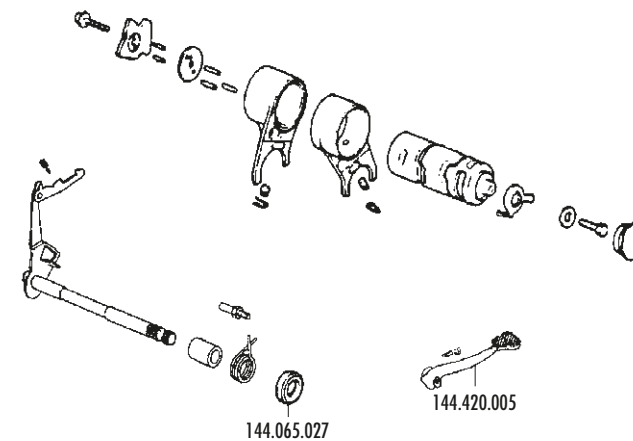

XP4 125 c.c.
dal telaio - from frame n° 0230
(da Febbraio-from February 2007)

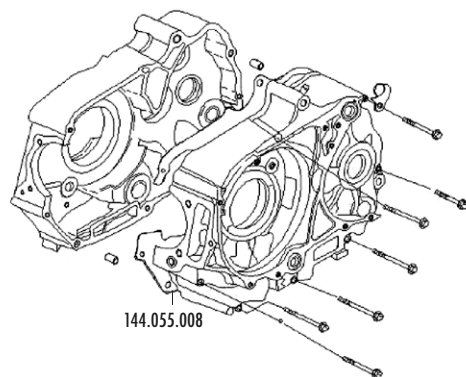
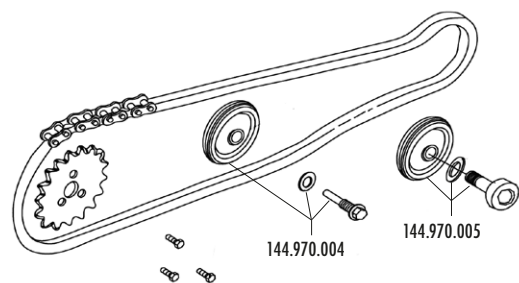
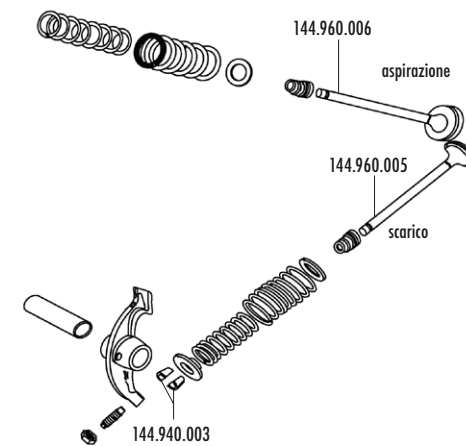
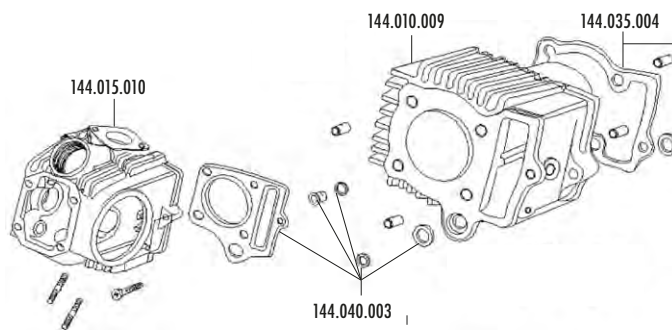
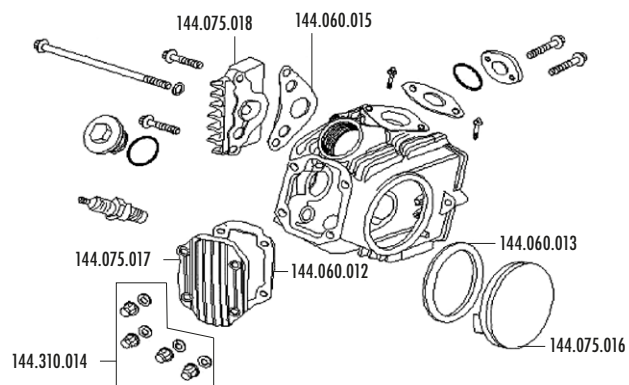

**XP4 125 c.c.
dal telaio - from frame n° 0230
(da Febbraio-from February 2007)**

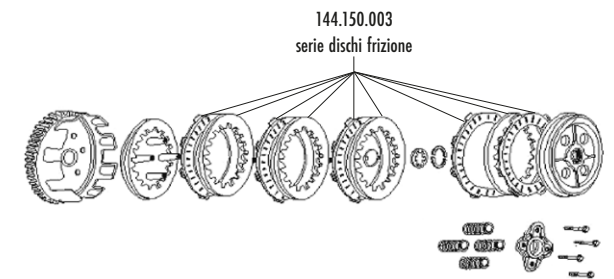
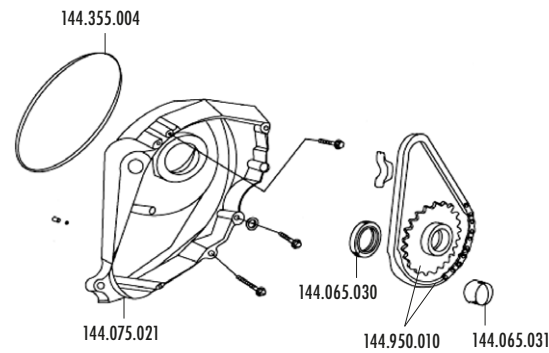
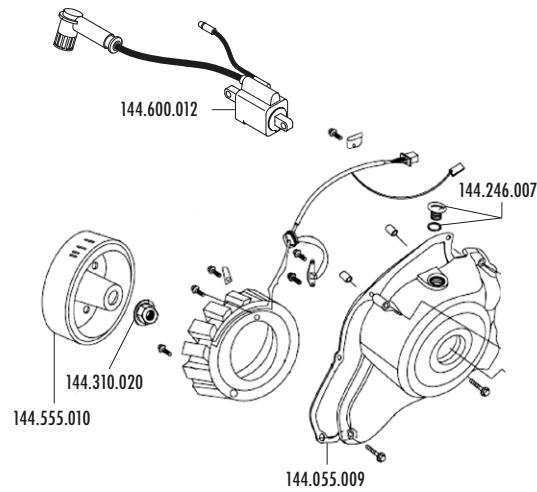
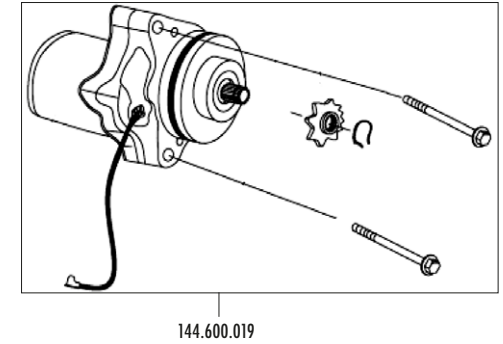
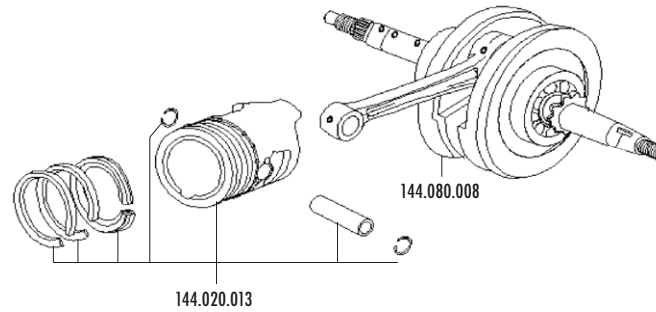
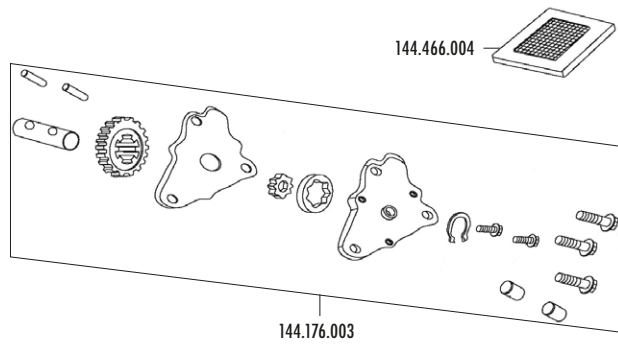

**XP4 125 c.c.
dal telaio - from frame n° 0230
(da Febbraio-from February 2007)**

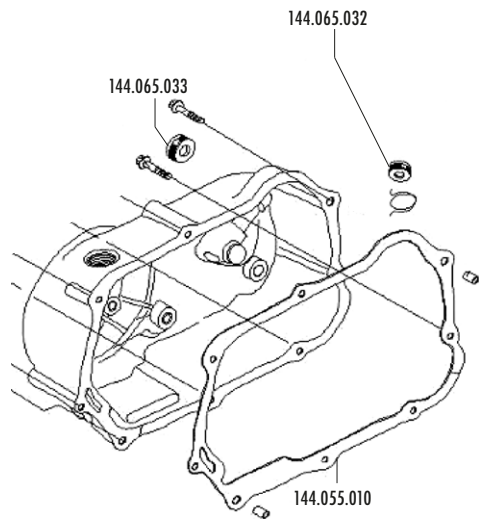

Z14= 144.290.214
Z15= 144.290.215
di serie Z16= 144.290.216

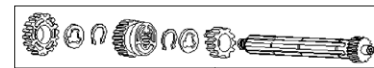

144.120.011

A+B+C= 144.112.005

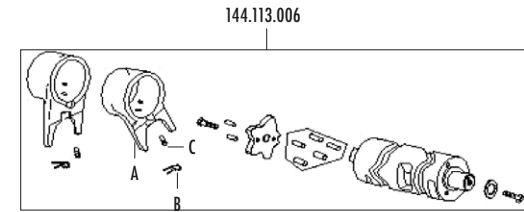

144.065.027

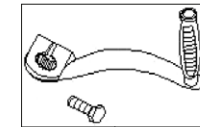

144.420.005

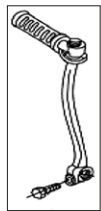

144.420.004



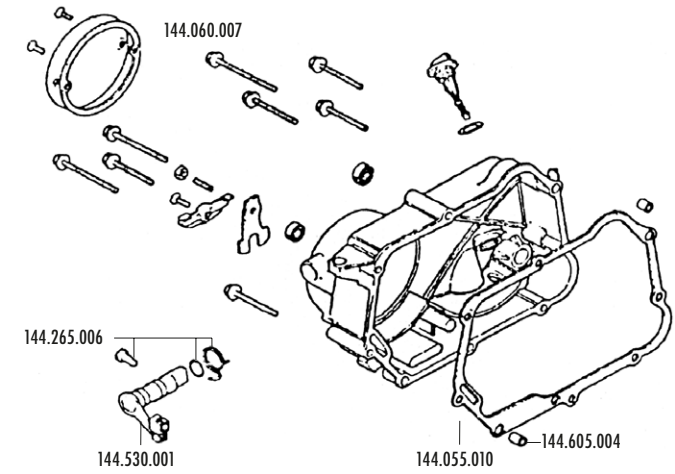
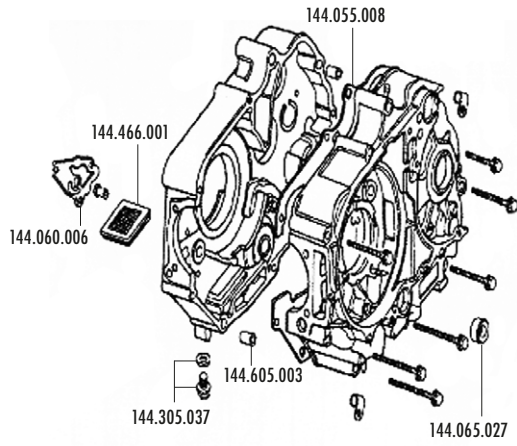
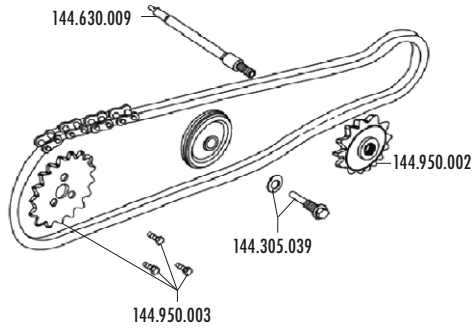
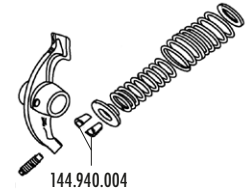
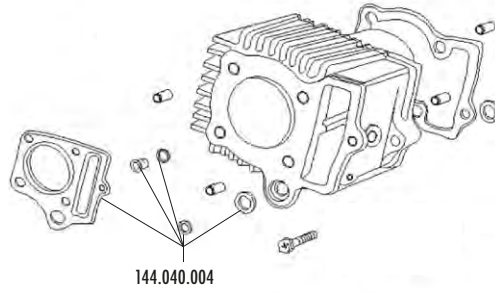
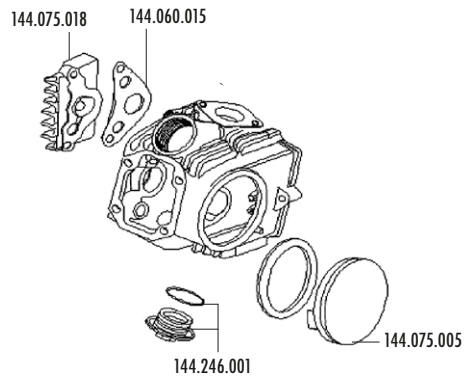

XP 4T 50 c.c.

A+B+C= 144.112.005

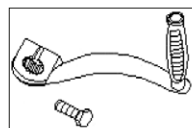
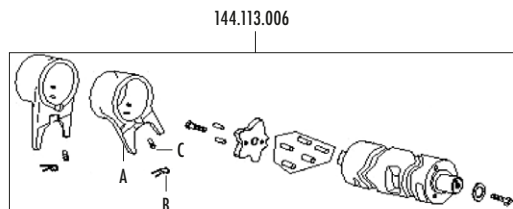

144.420.005

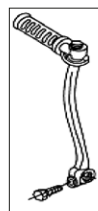

144.420.004

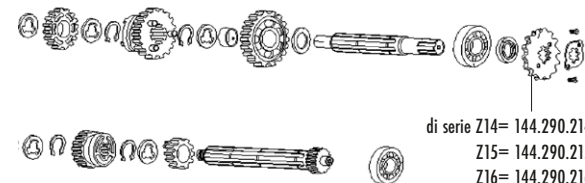

di serie Z14= 144.290.214
Z15= 144.290.215
Z16= 144.290.216

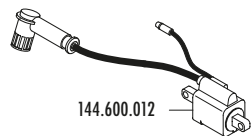

144.600.012

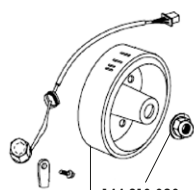

144.310.020

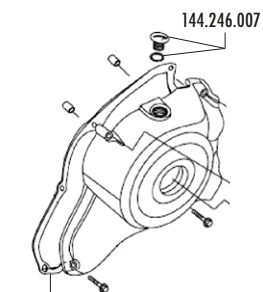

144.055.010

144.246.007

144.355.004

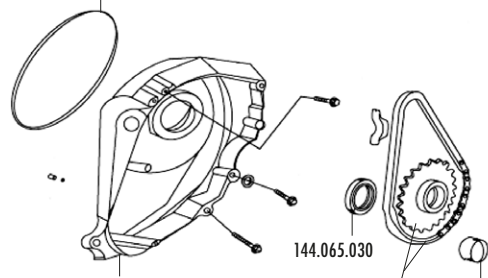

144.075.021

144.065.030

144.950.010

144.065.031

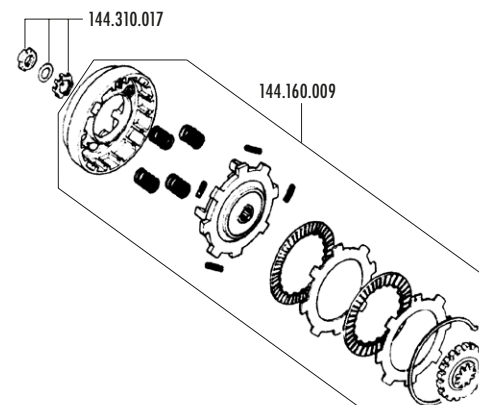

144.310.017

144.160.009

144.105.003

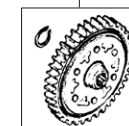

XP 4T 150 c.c.

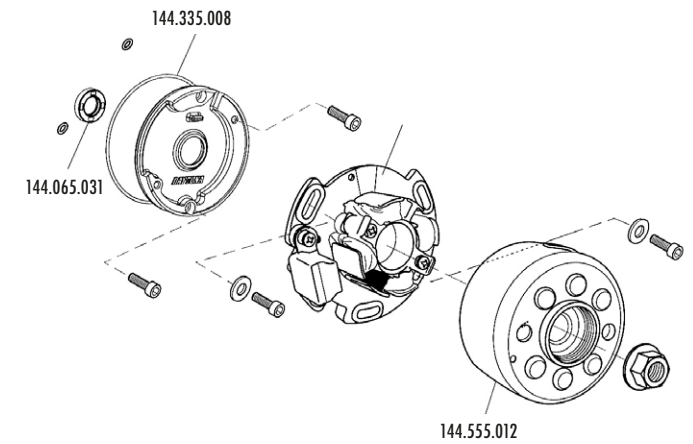
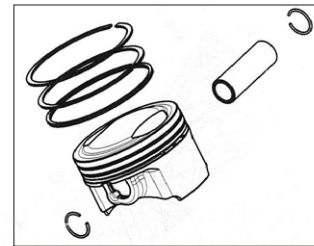
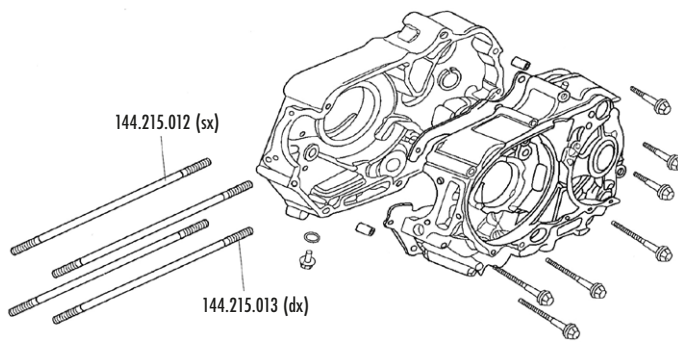
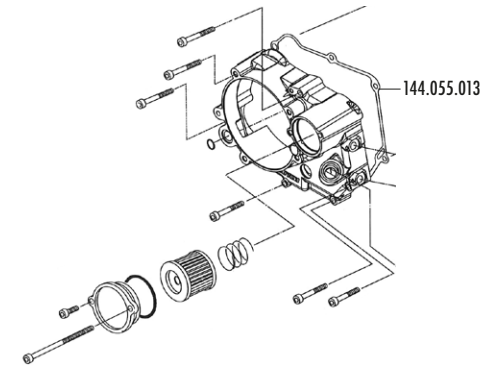
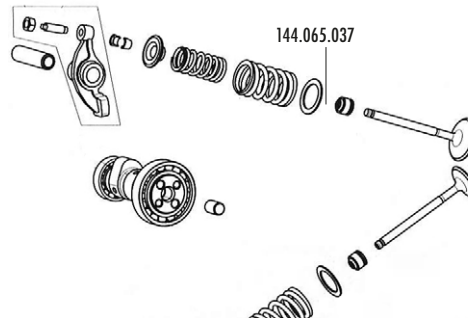
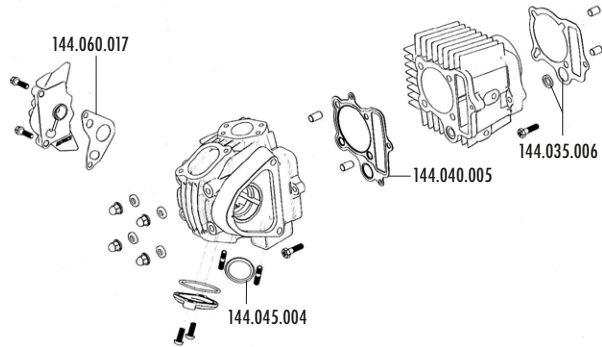

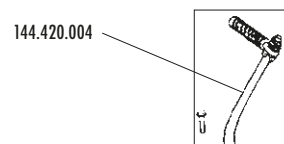
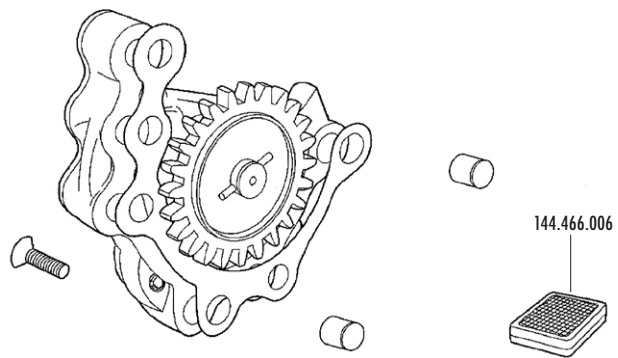

PIGNONE Z=16 144.290.216



RICAMBI XP 65 R

fino al telaio - up to frame

n° 162

ACCESSORI OPTIONALS

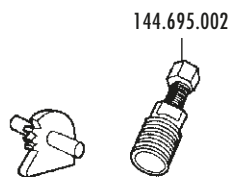

GRUPPO TERMICO CYLINDER KIT

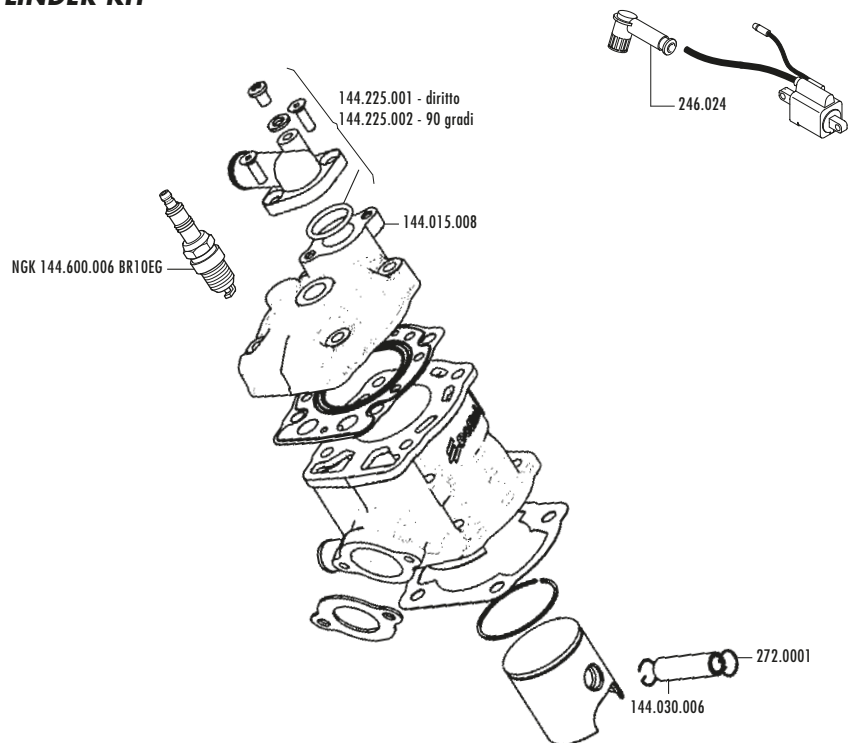

AVVIAMENTO STARTER

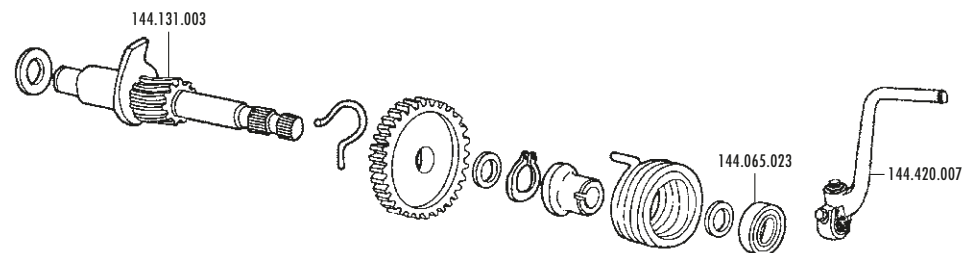

ACCENSIONE IGNITION

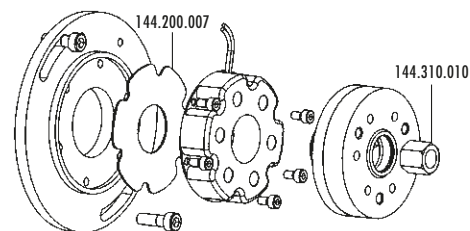

CARTER CRANKCASE

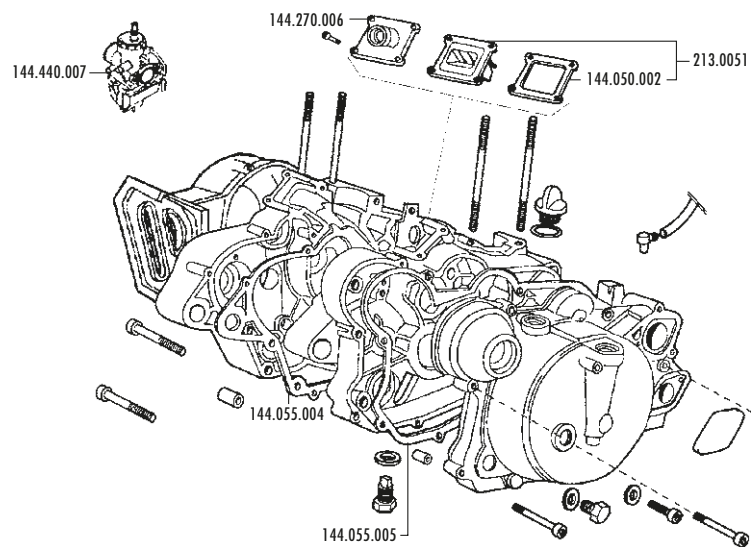

**POMPA ACQUA
WATER PUMP**

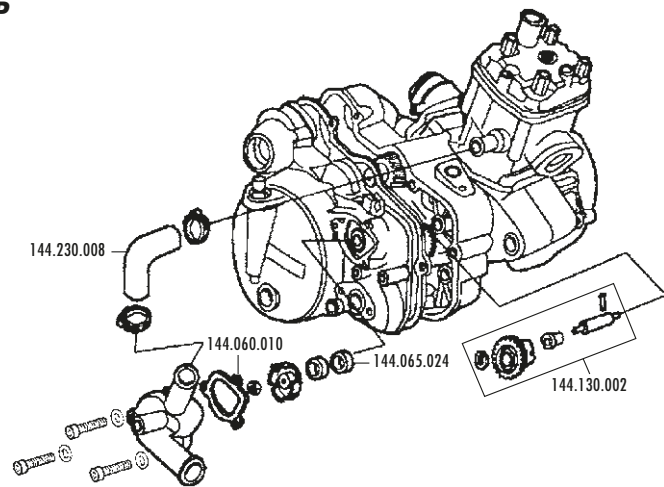

**CAMBIO
SHIFT**

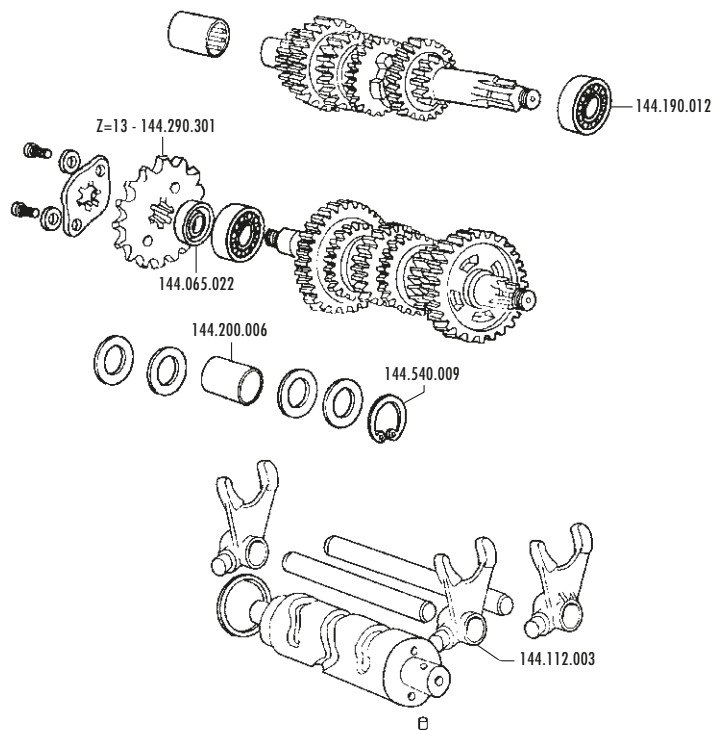

**RICAMBI XP 65 R
fino al telaio - up to frame
n°162**

**ALBERO MOTORE
CRANKSHAFT**

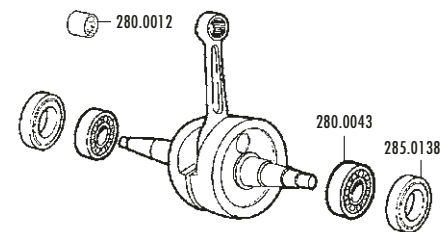

**FRIZIONE
CLUTCH**

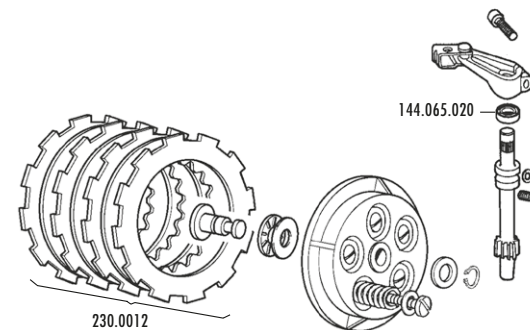

**SELETTORE CAMBIO
SHIFT SELECTOR**

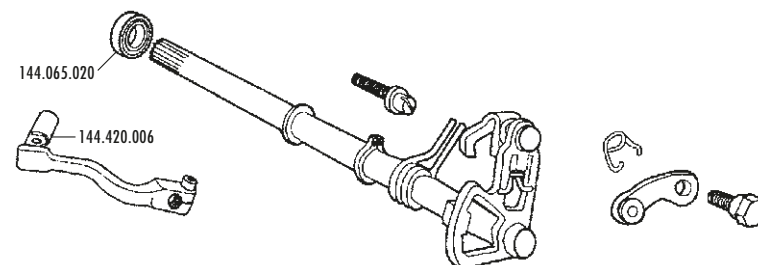

RICAMBI XP 65 R 2008

dal telaio - from frame n° 163

ACCESSORI
OPTIONALS

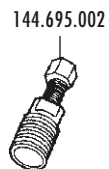

GRUPPO TERMICO CYLINDER KIT

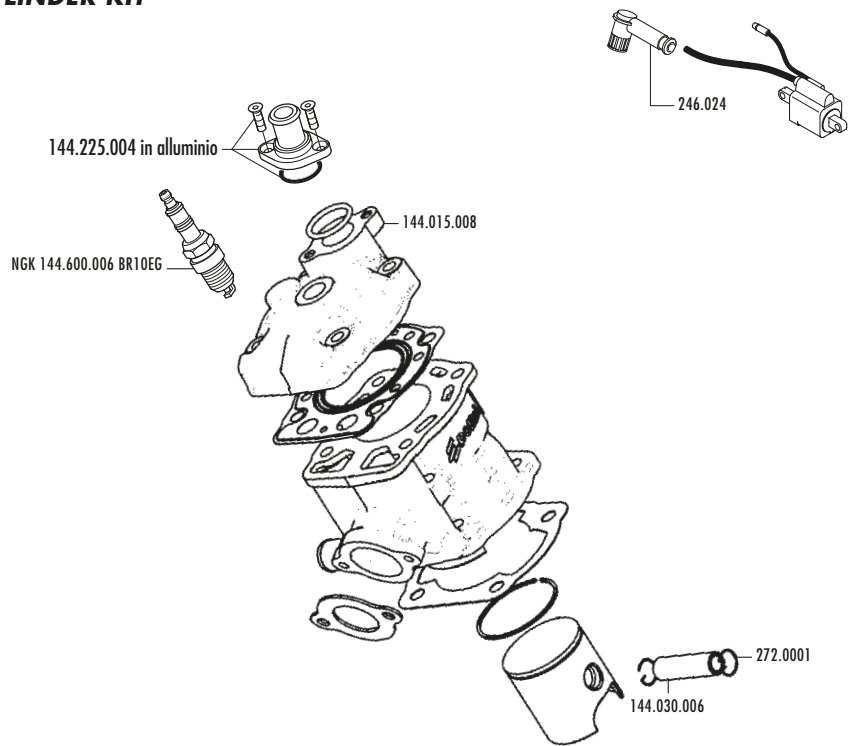

AVVIAMENTO STARTER

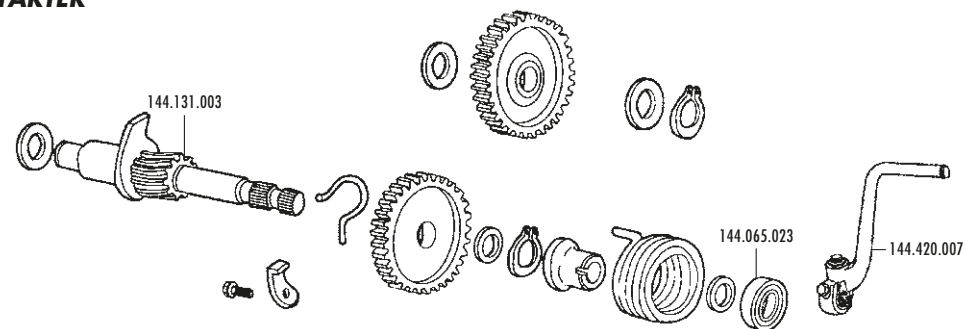

ACCENSIONE IGNITION

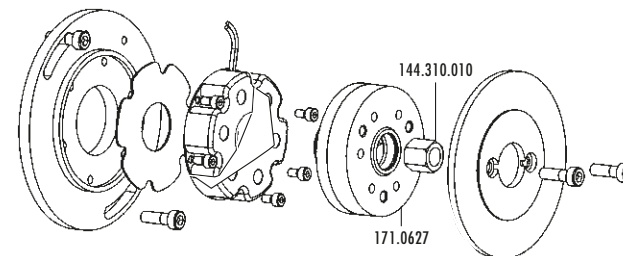

CARTER CRANKCASE

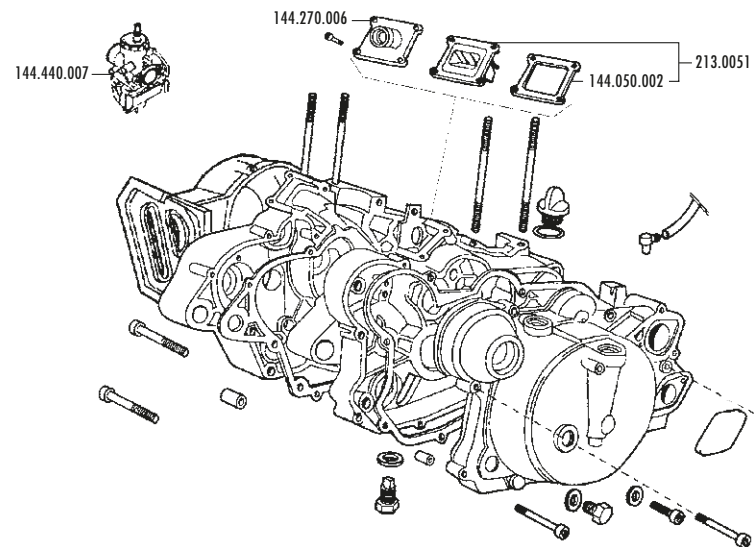

**POMPA ACQUA
WATER PUMP**

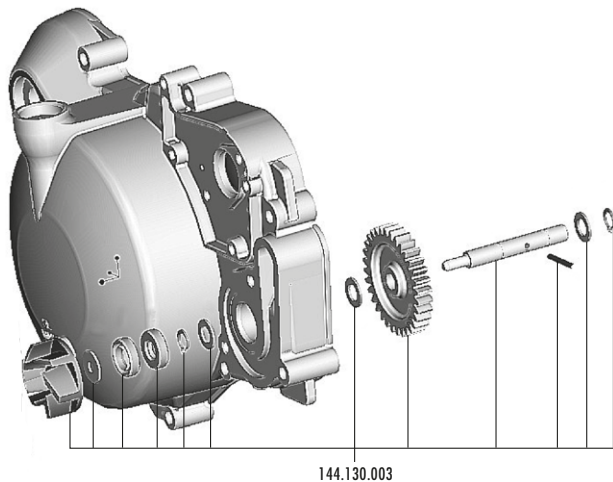

144.130.003

**CAMBIO
SHIFT**

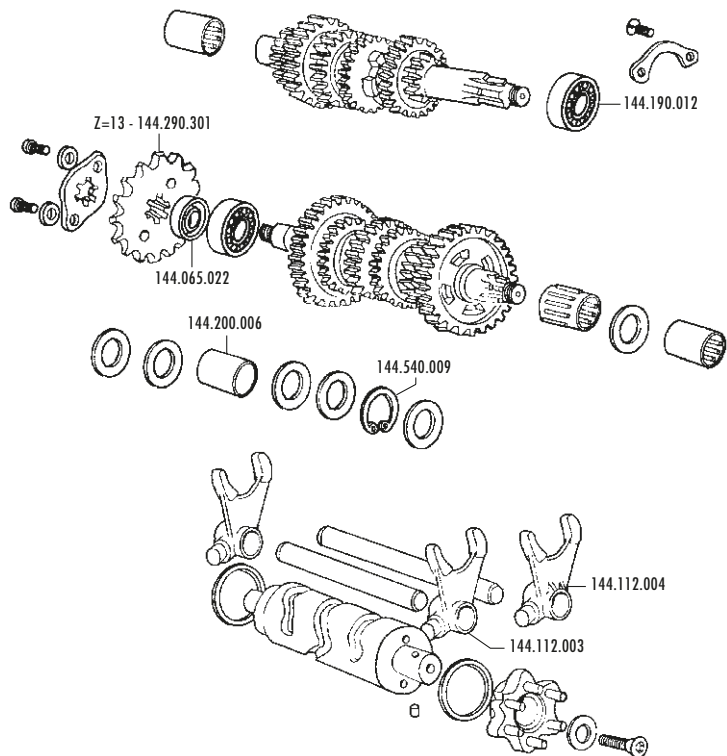

**RICAMBI XP 65 R 2008
dal telaio - from frame n° 163**

**ALBERO MOTORE
CRANKSHAFT**

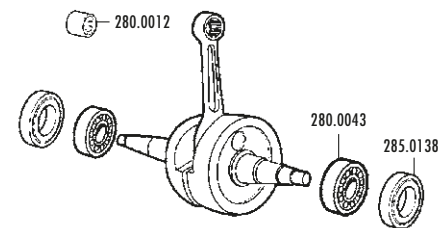

21

**FRIZIONE
CLUTCH**

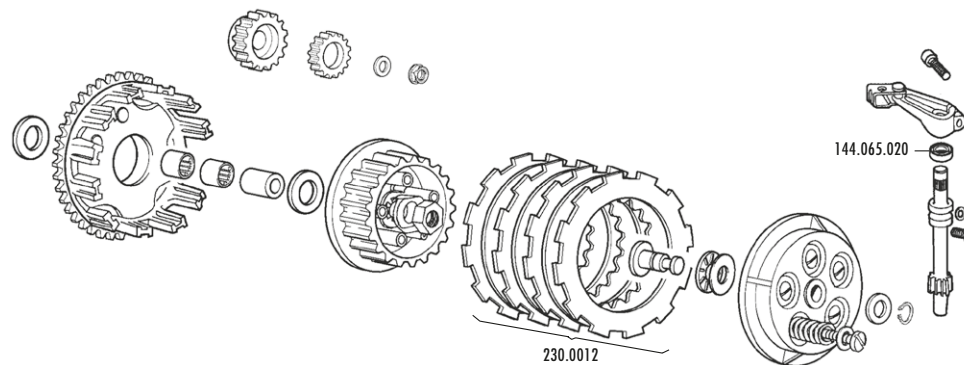

**SELETTORE CAMBIO
SHIFT SELECTOR**

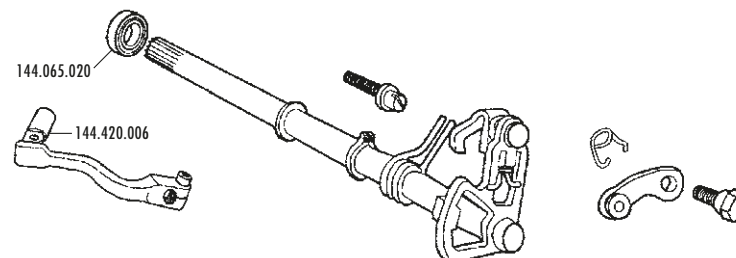

RICAMBI POLINI CP - CP POLINI SPARE PARTS

Ø19

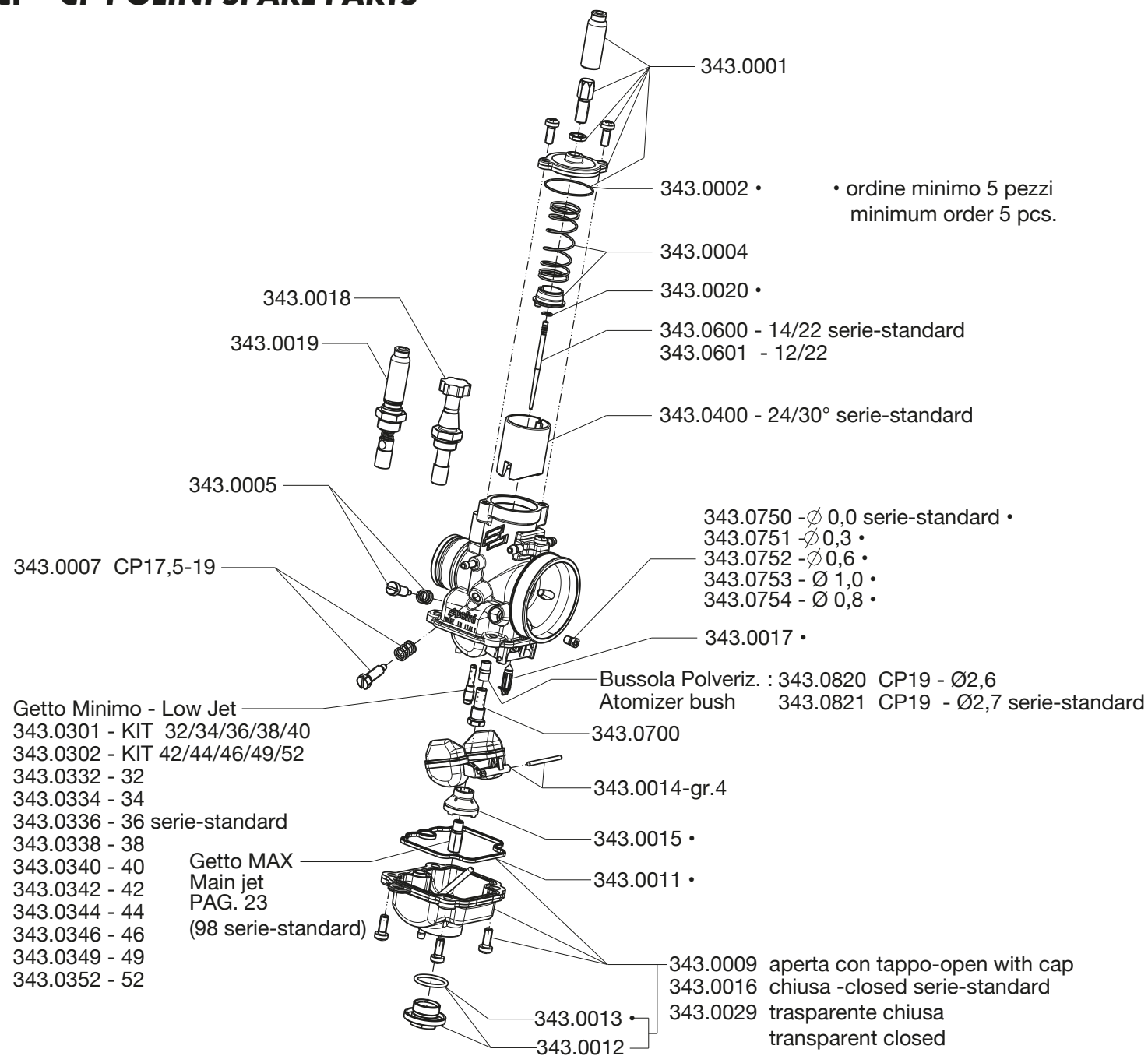

SET GETTI MASSIMO - MAIN JETS SET



CODICE - CODE	POLINI - KEIHIN - PWK MAIN JETS (set 10 pcs.)	INCREMENTO - INCREASE
370.0000	POLINI-KEIHIN-PWK dal 40 al 58 - from 40 to 58	2
370.0001	POLINI-KEIHIN-PWK dal 60 al 78 - from 60 to 78	2
370.0002	POLINI-KEIHIN-PWK dal 80 al 98 - from 80 to 98	2
370.0003	POLINI-KEIHIN-PWK dal 100 al 118 - from 100 to 118	2
370.0004	POLINI-KEIHIN-PWK dal 120 al 138 - from 120 to 138	2
370.0005	POLINI-KEIHIN-PWK dal 140 al 158 - from 140 to 158	2
370.0006	POLINI-KEIHIN-PWK dal 160 al 178 - from 160 to 178	2
370.0007	POLINI-KEIHIN-PWK dal 180 al 198 - from 180 to 198	2
370.0102	POLINI-KEIHIN-PWK dal 81 al 99 - from 81 to 99 (Dispari/Odd)	2
370.0103	POLINI-KEIHIN-PWK dal 101 al 119 - from 101 to 119 (Dispari/Odd)	2

GETTI MASSIMO (ordine minimo 5 pezzi) - MAIN JETS (minimum order 5 pcs.)



CODICE CODE	POLINI - KEIHIN - PWK (lotto 5 pcs.)
370.1040	POLINI-KEIHIN-PWK 40
370.1042	POLINI-KEIHIN-PWK 42
370.1044	POLINI-KEIHIN-PWK 44
370.1046	POLINI-KEIHIN-PWK 46
370.1048	POLINI-KEIHIN-PWK 48
370.1050	POLINI-KEIHIN-PWK 50
370.1052	POLINI-KEIHIN-PWK 52
370.1054	POLINI-KEIHIN-PWK 54
370.1056	POLINI-KEIHIN-PWK 56
370.1058	POLINI-KEIHIN-PWK 58
370.1060	POLINI-KEIHIN-PWK 60
370.1062	POLINI-KEIHIN-PWK 62

370.1064	POLINI-KEIHIN-PWK 64
370.1066	POLINI-KEIHIN-PWK 66
370.1068	POLINI-KEIHIN-PWK 68
370.1070	POLINI-KEIHIN-PWK 70
370.1072	POLINI-KEIHIN-PWK 72
370.1074	POLINI-KEIHIN-PWK 74
370.1076	POLINI-KEIHIN-PWK 76
370.1078	POLINI-KEIHIN-PWK 78
370.1080	POLINI-KEIHIN-PWK 80
370.1081	POLINI-KEIHIN-PWK 81
370.1082	POLINI-KEIHIN-PWK 82
370.1083	POLINI-KEIHIN-PWK 83
370.1084	POLINI-KEIHIN-PWK 84
370.1085	POLINI-KEIHIN-PWK 85
370.1086	POLINI-KEIHIN-PWK 86
370.1087	POLINI-KEIHIN-PWK 87
370.1088	POLINI-KEIHIN-PWK 88
370.1089	POLINI-KEIHIN-PWK 89
370.1090	POLINI-KEIHIN-PWK 90
370.1091	POLINI-KEIHIN-PWK 91
370.1092	POLINI-KEIHIN-PWK 92
370.1093	POLINI-KEIHIN-PWK 93
370.1094	POLINI-KEIHIN-PWK 94

370.1095	POLINI-KEIHIN-PWK 95
370.1096	POLINI-KEIHIN-PWK 96
370.1097	POLINI-KEIHIN-PWK 97
370.1098	POLINI-KEIHIN-PWK 98
370.1099	POLINI-KEIHIN-PWK 99
370.1100	POLINI-KEIHIN-PWK 100
370.1101	POLINI-KEIHIN-PWK 101
370.1102	POLINI-KEIHIN-PWK 102
370.1103	POLINI-KEIHIN-PWK 103
370.1104	POLINI-KEIHIN-PWK 104
370.1105	POLINI-KEIHIN-PWK 105
370.1106	POLINI-KEIHIN-PWK 106
370.1107	POLINI-KEIHIN-PWK 107
370.1108	POLINI-KEIHIN-PWK 108
370.1109	POLINI-KEIHIN-PWK 109
370.1110	POLINI-KEIHIN-PWK 110
370.1111	POLINI-KEIHIN-PWK 111
370.1112	POLINI-KEIHIN-PWK 112
370.1113	POLINI-KEIHIN-PWK 113
370.1114	POLINI-KEIHIN-PWK 114
370.1115	POLINI-KEIHIN-PWK 115
370.1116	POLINI-KEIHIN-PWK 116
370.1117	POLINI-KEIHIN-PWK 117

370.1118	POLINI-KEIHIN-PWK 118
370.1119	POLINI-KEIHIN-PWK 119
370.1120	POLINI-KEIHIN-PWK 120
370.1122	POLINI-KEIHIN-PWK 122
370.1124	POLINI-KEIHIN-PWK 124
370.1126	POLINI-KEIHIN-PWK 126
370.1128	POLINI-KEIHIN-PWK 128
370.1130	POLINI-KEIHIN-PWK 130
370.1132	POLINI-KEIHIN-PWK 132
370.1134	POLINI-KEIHIN-PWK 134
370.1136	POLINI-KEIHIN-PWK 136
370.1138	POLINI-KEIHIN-PWK 138
370.1140	POLINI-KEIHIN-PWK 140
370.1142	POLINI-KEIHIN-PWK 142
370.1144	POLINI-KEIHIN-PWK 144
370.1146	POLINI-KEIHIN-PWK 146
370.1148	POLINI-KEIHIN-PWK 148
370.1150	POLINI-KEIHIN-PWK 150
370.1152	POLINI-KEIHIN-PWK 152
370.1154	POLINI-KEIHIN-PWK 154
370.1156	POLINI-KEIHIN-PWK 156
370.1158	POLINI-KEIHIN-PWK 158
370.1160	POLINI-KEIHIN-PWK 160

370.1162	POLINI-KEIHIN-PWK 162
370.1164	POLINI-KEIHIN-PWK 164
370.1166	POLINI-KEIHIN-PWK 166
370.1168	POLINI-KEIHIN-PWK 168
370.1170	POLINI-KEIHIN-PWK 170
370.1172	POLINI-KEIHIN-PWK 172
370.1174	POLINI-KEIHIN-PWK 174
370.1176	POLINI-KEIHIN-PWK 176
370.1178	POLINI-KEIHIN-PWK 178
370.1180	POLINI-KEIHIN-PWK 180
370.1182	POLINI-KEIHIN-PWK 182
370.1184	POLINI-KEIHIN-PWK 184
370.1186	POLINI-KEIHIN-PWK 186
370.1188	POLINI-KEIHIN-PWK 188
370.1190	POLINI-KEIHIN-PWK 190
370.1192	POLINI-KEIHIN-PWK 192
370.1194	POLINI-KEIHIN-PWK 194
370.1196	POLINI-KEIHIN-PWK 196
370.1198	POLINI-KEIHIN-PWK 198