

VESPA PX 125-150 - PX200E HT CLUTCH
FRIZIONE HT VESPA PX 125-150 - PX200E

HIGH TORQUE CLUTCH FOR RACE

NEW!

SPECIAL ALLOY
ALUMINUM BASKET

CESTELLO ALLUMINIO
LEGA SPECIALE

DISCS WITH INCREASED
DRAG SURFACE

DISCHI CON SUPERFICIE
TRASCINAMENTO
MAGGIORATO

CLUTCH PRESSURE PLATE
ON AXIAL BEARING

SPINGIDISCO SU
CUSCINETTO ASSIALE

COVER WITH OIL
COLLECTION GROOVE

COPERCHIO CON CANALE
RACCOLTA OLIO



Born from Endurance competitions, the HT For Race clutch represents the pinnacle of technology for the Vespa PX or PE. Thanks to its innovative reversed operation layout, the part connected to the crankshaft is no longer the external bell, but the internal hub. The main characteristics are:

Precise and smooth gear shift for effortless gear changes.

The 8-tooth aluminium discs maximize transmission efficiency and guarantee greater transmitted power.

Possibility to adjust the clutch spring load and choose the optimal teeth of the primary gear to adapt the ratios.

The HT clutch fits the original cover with only minimal modification.

Nata dalle competizioni Endurance, la frizione HT For Race rappresenta l'apice della tecnologia per la Vespa PX o PE. Grazie al suo innovativo layout a funzionamento invertito, la parte collegata all'albero motore non è più la campana esterna, ma il mozzo interno. Le caratteristiche principali sono:

Innesto marce preciso e fluido per un cambio marcia senza sforzo.

I dischi in alluminio a 8 denti massimizzano l'efficienza della trasmissione e garantiscono maggiore potenza trasmessa.

Possibilità di regolare il carico molla della frizione e scegliere le dentature ottimali dell'ingranaggio primario per adattare i rapporti.

La frizione HT si adatta al coperchio originale solo con una minima modifica.



ASSEMBLY SEQUENCE FOR VESPA PX 125/150 - PX 200E HT CLUTCH

SEQUENZA DI MONTAGGIO PER FRIZIONE HT VESPA PX 125/150 - PX 200E

It is possible to assembly it also with 202.0000 - 202.0001
 Possibile montaggio anche con 202.0000 - 202.0001



202.0002 Polini straight teeth riveting primary gear Vespa PX125/150/200E
Z=64 *Primaria Polini Vespa PX125/150/200E chiodata denti dritti*

NEW!



230.0530 Polini clutch For Race Vespa PX 125/150/200E with Z.24 straight teeth sprocket for Polini Z.64 primary gear
Z=24 *Frizione Polini For Race Vespa PX 125/150/200E con pignone Z.24 denti dritti per primaria Polini Z.64*

230.0531 Polini clutch For Race Vespa PX 125/150/200E with Z.23 straight teeth sprocket for Polini Z.64 primary gear
Z=23 *Frizione Polini For Race Vespa PX 125/150/200E con pignone Z.23 denti dritti per primaria Polini Z.64*

230.0532 Polini clutch For Race Vespa PX 125/150/200E with Z.22 straight teeth sprocket for Polini Z.64 primary gear
Z=22 *Frizione Polini For Race Vespa PX 125/150/200E con pignone Z.22 denti dritti per primaria Polini Z.64*



PIAGGIO ORIGINAL Vespa PX 125/150/200E helical teeth
Z=67 *Vespa PX 125/150/200E denti elicoidali*

PIAGGIO ORIGINAL Vespa PX 125/150/200E helical teeth
Z=68 *Vespa PX 125/150/200E denti elicoidali*

NEW!



230.0533 Polini clutch For Race Vespa PX 125/150/200E with helical teeth sprocket for original Piaggio Z.67/68 primary gear
Z=23 *Frizione Polini For Race Vespa PX 125/150/200E pignone denti elicoidali per primaria Z.67/68 originali Piaggio*



PIAGGIO ORIGINAL Vespa PX 125/150/200E helical teeth
Z=65 *Vespa PX 125/150/200E denti elicoidali*

NEW!



230.0534 Polini clutch For Race Vespa PX 125/150/200E with helical teeth sprocket for original Piaggio Z.65 primary gear
Z=22 *Frizione Polini For Race Vespa PX 125/150/200E con pignone denti elicoidali per primaria Z.65 originale Piaggio*

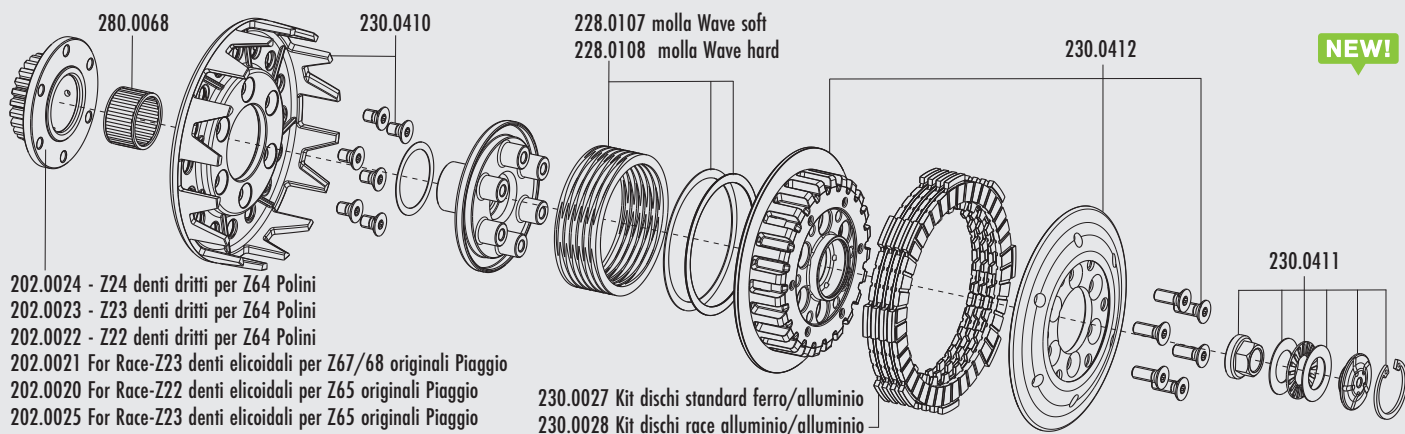

NEW!